

# KAMAZ





## TRUCKS



© Advertising T&FC KAMAZ

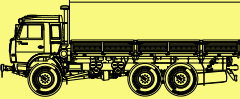
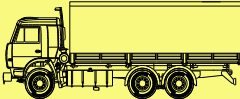
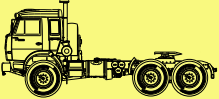

## KAMAZ VEHICLES COMBINED LIST

Vehicle Image	Truck Type	Model	Wheel Arrangement	Carrying Capacity (Fifth Coupler Load), kg	Truck Allowed Gross Weight, kg	Cab Type	Engine Model	Number of Gearbox Gears	Base, mm
	truck	4326	4ō4	4000	11600	S	1	5	4200
	truck	43114	6ō6	6090	15420	S, L	1, 2	5	3340
	truck	43118	6ō6	10000	20700	S, L	2	10	3690
	truck	53215	6ō4	11000	19355	L	1, 2	10	3690
	truck	6350	8ō8	14000	26300	L	3	16	3340
	truck	65115	6ō4	15000	24000	S, L	2	10	3690; 4970
	tractor truck	44108	6ō6	10000	32000	L	2	10	3690
	tractor truck	54115	6ō4	12000	34150	L	1, 2	10	2840
	tractor truck	5460	4ō2	10800	40000	L	3	16	3950
	tractor truck	6460	6ō4	16600	46000	L	3	16	3020
	tractor truck	65115	6ō4	15000	36600	L	2	10	2840
	dump truck	55111	6ō4	13000	22200	S	1, 2	10	2840
	dump truck	65111	6ō6	14000	24500	S	2	5	3340
	dump truck	65115	6ō4	15000	24800	S	1, 2	10	2840
	dump truck	6520	6ō4	20000	33100	S	4	16	3600
	dump truck	6522	6ō6	19000	33100	S	4	16	3600
	dump truck	6540	8ō4	18500	30500	S	2	10	2080

Cab: **S**- short cab, without a sleeper;

**L**- long cab, with a sleeper;

Engine: **1**- engine KAMAZ-740.11, power: 176 kwt (240 H.P.), peak torque: 833 Nm, Euro-1;

**2**- engine KAMAZ-740.13, power: 191 kwt (260 H.P.), peak torque: 931 Nm, Euro-1;

**3**-engine KAMAZ-740.50, power: 265 kwt (360 H.P.), peak torque: 1434 Nm, Euro-2;

**4**-engine KAMAZ-740.51, power: 235 kwt (320 H.P.), peak torque: 1225 Nm, Euro-2;

**5**-engine KAMAZ-740.30, power: 191 kwt (260 H.P.), peak torque: 1079 Nm, Euro-2

# KAMAZ-4326



© Advertising T&C KAMAZ



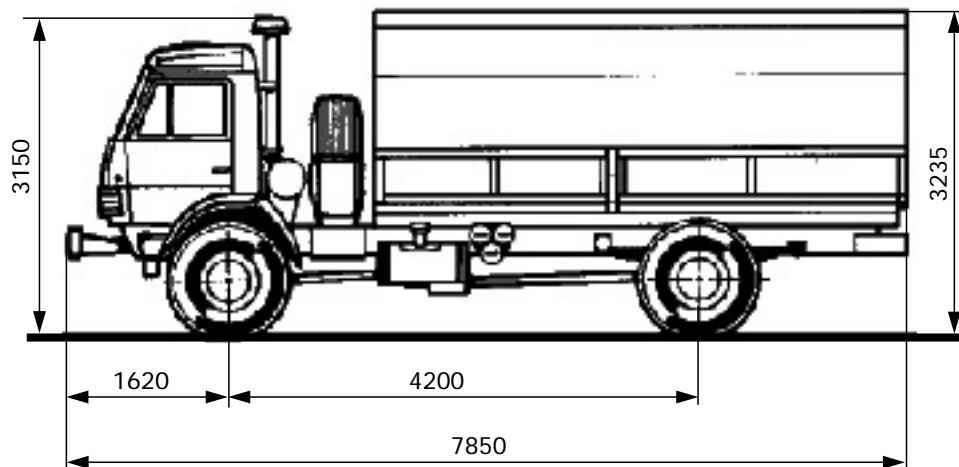

## KAMAZ - 4326 (4x4)

### Specifications

#### Weights and Load Capacities:

Vehicle load carrying capacity, kg.....	4000
Gross weight, kg.....	11600
Front axle load, kg.....	5600
Rear axle load, kg.....	6000
Trailer gross weight, kg.....	7000 (for hard road 5000)
Road train allowed gross weight, kg.....	18600 (for hard road 16600)

#### Engine:

Model.....	740.11-240
Type.....	diesel, turbocharged
Rated horsepower, kwt (H.P.).....	176 (240)
at crankshaft rotation, rpm.....	2200
Maximum torque, Nm (kgcm).....	834 (85)
at crankshaft rotation, rpm.....	1200-1600
Arrangement and number of cylinders.....	V-shape, 8
Displacement, l.....	10.85
Cylinder diametre and piston stroke, mm.....	120/120
Compression ratio.....	16

#### Electrics:

Voltage, V.....	24
Storage batteries, V/Ah.....	2x12/190
Generator, V.....	28

#### Clutch:

Type.....	friction, dry, two-plate, mod. 142
Drive.....	hydraulic with pneumatic booster

#### Gearbox:

Type.....	mechanical, five-speed
Control.....	mechanical, remote

#### Gear ratios at gears:

1	2	3	4	5	Rev.
7.82	4.03	2.50	1.53	1.00	7.38

#### Transfer Case:

Type.....	mechanical, two-speed with lockable interaxle differential
Control.....	pneumatic
Gear ratio of high/low gears.....	1.692/0.917

#### Brakes:

Drive.....	pneumatic
Size: drum diametre, mm.....	400
Brake linings width, mm.....	140
Brake linings total area, sq. cm.....	4200

#### Wheels and Tyres:

Wheel type.....	disc
Tyre type.....	pneumatic, pressure adjustment
Rim size.....	12,2-20.9 (310-533)
Tyre size.....	425/85 R21 (1260x425-533P)

#### Cab:

Type.....	front, above engine, three-seat
Execution.....	short (sleeper)

#### Platform:

Type.....	metal, drop-sided, equipped with removable canopy and frame
Inside length, mm.....	4800 (5200)
Inside width, mm.....	2320

#### Specification of 11600 kg gross weight vehicle:

Maximum speed, not less, km/h.....	90
Maximum gradient, not less, (%).....	31 (60)

#### KAMAZ Incorporated

29, M. Dzhilil av., Naberezhnye Chelny,  
Tatarstan, Russian Federation, 423808  
phone: +7(8552) 42-2665, 55-4086  
fax: +7(8552) 55-4167  
<http://www.kamaz.net>



#### Foreign Trade Company KAMAZ

Naberezhnye Chelny:  
phone.: +7(8552) 53-2404, phone/fax: 37-1816  
Moscow: phone/fax: +7(095) 911-3134  
E-mail: [agesk@kamaztrade.ru](mailto:agesk@kamaztrade.ru)  
<http://www.kamaztrade.ru>

# KAMAZ-43114



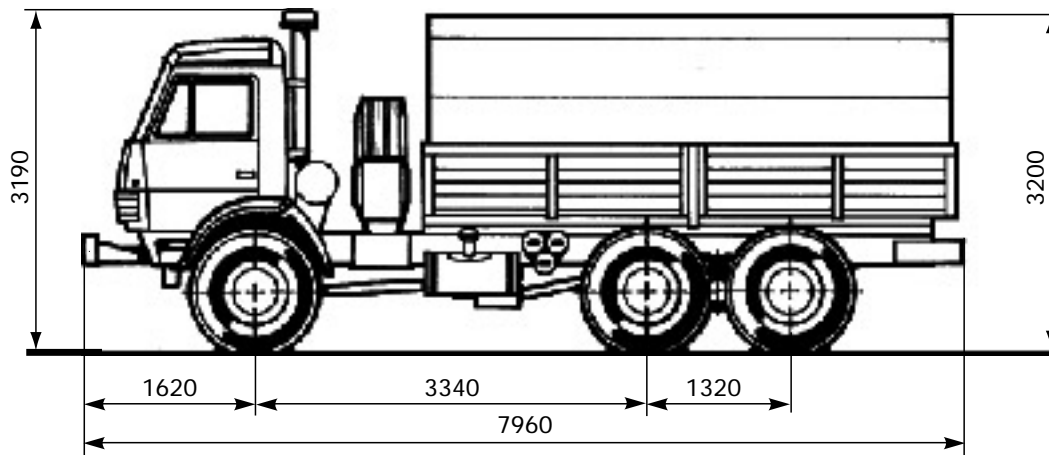

## KAMAZ - 43114 (6x6)

### Specifications

#### Weights and Load Capacities:

Vehicle load carrying capacity, kg.....	6090
Gross weight, kg.....	15420
Front axle load, kg.....	5490
Rear bogie load, kg.....	9930
Trailer gross weight, kg.....	12000(for hard road 7500)
Road train allowed gross weight, kg.....	27450 (for hard road 22950)

#### Engine:

Model.....	740.13-260 (EURO-1)
Type.....	diesel, turbocharged
Rated horsepower, kwt (H.P.).....	191 (260)
at crankshaft rotation, rpm.....	2200
Maximum torque, Nm (kgcm).....	931 (95)
at crankshaft rotation, rpm.....	1300-1500
Arrangement and number of cylinders.....	V-shape, 8
Displacement, l.....	10.85
Cylinder diameter and piston stroke, mm.....	120/120
Compression ratio.....	17

#### Electrics:

Voltage, V.....	24
Storage batteries, V/Ah.....	2x12/190
Generator, V.....	28

#### Clutch:

Type.....	friction, dry, two-plate, mod. 17
Drive.....	hydraulic with pneumatic booster

#### Gearbox:

Type.....	mechanical, five-speed				
Control.....	mechanical, remote				
Gear ratios at gears:					
1	2	3	4	5	Rev.
7.82	4.03	2.50	1.53	1.00	7.38

#### Transfer Case:

Type.....	mechanical, two-speed with lockable interaxle differential
Control.....	pneumatic
Gear ratio of high/low gears.....	1.692/0.917

#### Brakes:

Drive.....	pneumatic
Size: drum diameter, mm.....	400
Brake linings width, mm.....	140
Brake linings total area, sq. cm.....	6300

#### Wheels and Tyres:

Wheel type.....	disk
Tyre type.....	pneumatic, pressure adjustment
Rim size.....	12.2-20,9 (310-533)
Tyre size.....	425/85 R21 (1260x425-533P)

#### Cab:

Type.....	front, above engine, three-seat
Option.....	short (sleeper)

#### Platform:

Type.....	metal, drop-sided, equipped with removable canopy and frame
Inside length, mm.....	4800 (5200)
Inside width, mm.....	2320

#### Specification of 15420 kg gross weight vehicle:

Maximum speed, not less, km/h.....	90
Maximum gradient, not less, (%).....	31(60)

#### KAMAZ Incorporated

29, M. Dzhilil av., Naberezhnye Chelny,  
Tatarstan, Russian Federation, 423808  
phone: +7(8552) 42-2665, 55-4086  
fax: +7(8552) 55-4167  
<http://www.kamaz.net>



#### Foreign Trade Company KAMAZ

Naberezhnye Chelny:  
phone.: +7(8552) 53-2404, phone/fax: 37-1816  
Moscow: phone/fax: +7(095) 911-3134  
E-mail: [agesk@kamaztrade.ru](mailto:agesk@kamaztrade.ru)  
<http://www.kamaztrade.ru>

# KAMAZ-43118



© Advertising T&C KAMAZ



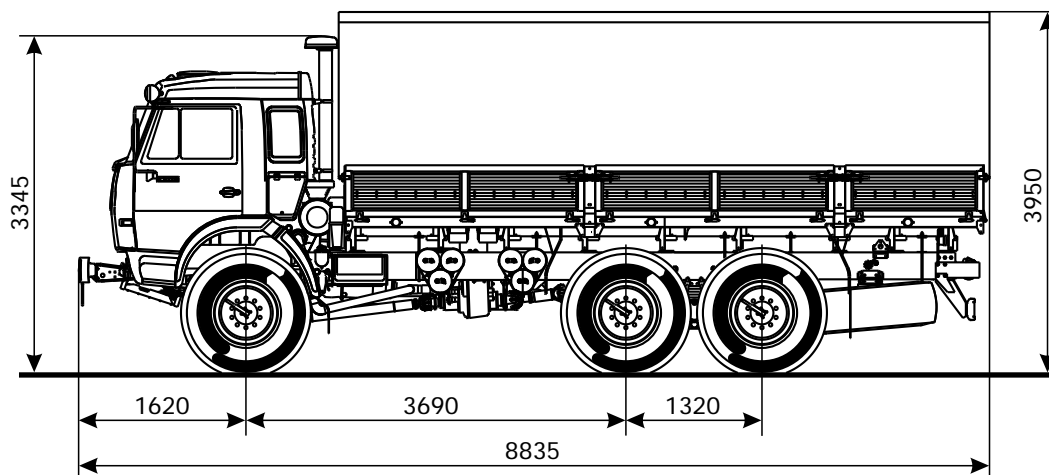

## KAMAZ - 43118 (6x6)

### Specifications

#### Weights and Load Capacities:

Vehicle load carrying capacity, kg.....	10000
Gross weight, kg.....	20700
Front axle load, kg.....	5550
Rear bogie load, kg.....	15150
Trailer gross weight, kg.....	12000
Road train gross weight, kg.....	32700

#### Engine:

Model.....	740.13-260 (E-1)
Type.....	diesel, turbocharged
Rated horsepower, kwt (H.P.).....	191 (260)
at crankshaft rotation, rpm.....	2200
Maximum torque, Nm (kgcm).....	931 (95)
at crankshaft rotation, rpm.....	1300-1500
Arrangement and number of cylinders.....	V-shape, 8
Displacement, l.....	10.85
Cylinder diametre and piston stroke, mm.....	120/120
Compression ratio.....	17

#### Electrics:

Voltage, V.....	24
Storage batteries, V/Ah.....	2x12/190
Generator, V.....	28

#### Clutch:

Type.....	diaphragm, two-plate, mod.17
Drive.....	hydraulic with pneumatic booster

#### Gearbox:

Type.....	mechanical, ten-speed
Control.....	mechanical, remote

#### Gear ratios at gears:

1	2	3	4	5	Rev.
7.82	4.03	2.50	1.53	1.00	7.38
6.38	3.29	2.04	1.25	0.815	6.02

#### Transfer Case:

Type.....	mechanical, two-speed with lockable interaxle differential
Control.....	pneumatic
Gear ratio of high/low gears.....	1.692/0.917

#### Brakes:

Drive.....	pneumatic
Size: drum diametre, mm.....	400
Brake linings width, mm.....	140
Brake linings total area, sq.cm.....	6300

#### Wheels and Tyres:

Wheel type.....	disk
Tyre type.....	pneumatic, pressure adjustment
Rim size.....	12.2-20.9 (310-533)
Tyre size.....	425/85 R21 (1260x425-533P)

#### Cab:

Type.....	front, above engine, three-seat
Option.....	with a sleeper (short)

#### Platform:

Type.....	vehicle-borne, metal with removable benches, equipped with removable canopy and frame
Inside length, mm.....	6100 (5200)
Inside width, mm.....	2320

#### Specification of 20700 kg gross weight vehicle:

Maximum speed, not less, km/h.....	90
Maximum gradient, not less, (%).....	28 (53)

#### KAMAZ Incorporated

29, M. Dzhailil av., Naberezhnye Chelny,  
Tatarstan, Russian Federation, 423808  
phone: +7(8552) 42-2665, 55-4086  
fax: +7(8552) 55-4167  
<http://www.kamaz.net>



#### Foreign Trade Company KAMAZ

Naberezhnye Chelny:  
phone.: +7(8552) 53-2404, phone/fax: 37-1816  
Moscow: phone/fax: +7(095) 911-3134  
E-mail: [agesk@kamaztrade.ru](mailto:agesk@kamaztrade.ru)  
<http://www.kamaztrade.ru>



# KAMAZ-4911



**NEW**



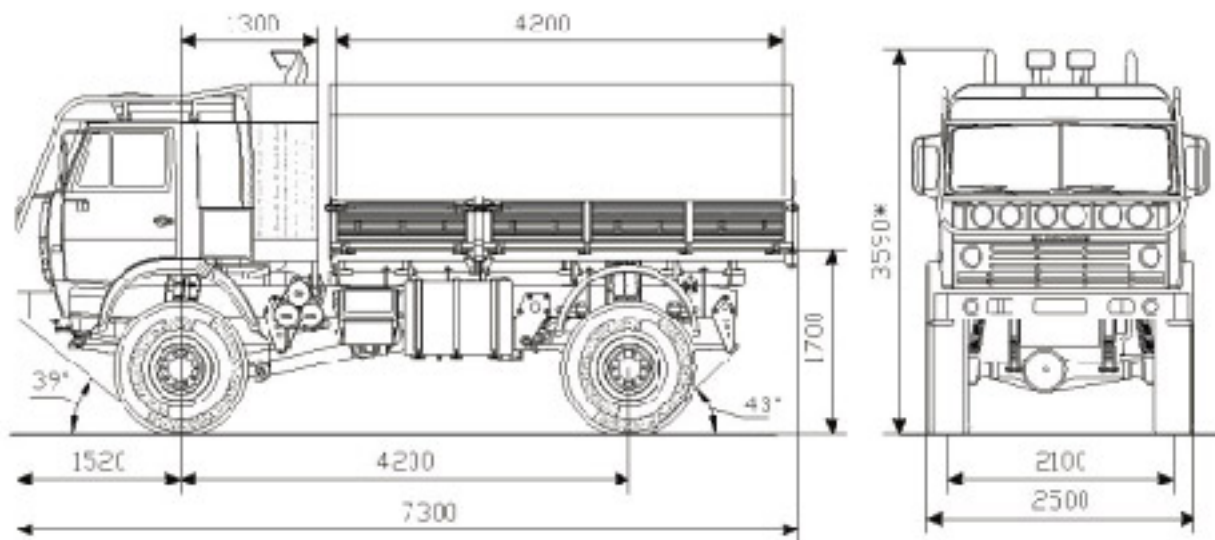

## KAMAZ - 4911 (4x4)

### Specifications

#### Weights and Load Capacities:

Curb weight.....10400  
 Vehicle load carrying capacity, kg.....5000  
 Gross weight, kg.....15600

#### Engine:

Model.....YMZ-7Y846  
 Type.....diesel, turbocharged  
 Rated horsepower, kw (H.P.).....538 (730)  
 at crankshaft rotation, rpm.....2500  
 Maximum torque, Nm.....2700  
 at crankshaft rotation, rpm.....1300-1400  
 Arrangement and number of cylinders.....V-shape, 8  
 Displacement, l.....17,24  
 Cylinder diameter and piston stroke, mm.....140/140  
 Compression ratio.....15,2

#### Fuel System:

Fuel tank capacity, l.....400+ 400

#### Electrics:

Voltage, V.....24  
 Storage batteries, V/Ah.....2x12/190  
 Generator, V.....28

#### Clutch:

Type.....friction, dry, one-plate  
 Drive.....hydraulic with pneumatic booster  
 Linings diameter, mm.....430

#### Gearbox:

Model....."ZF" 16S-251  
 Type.....mechanical, 16-speed  
 Control.....mechanical, remote

#### Transfer Case:

Model....."STEYR" VG2000/300

#### Final Drive:

Gear ratio.....3,55

#### Brakes:

Drive.....pneumatic  
 Size: drum diameter, mm.....400  
 Brake linings width, mm.....220

#### Wheels and Tyres:

Wheel type.....disc  
 Tyre type.....pneumatic, pressure adjustment  
 Rim size.....12,2-20.9 (310-533)  
 Tyre size.....425/85 R21 (1260x425-533P)  
 156G 14R20 (MICHELIN)

#### Cab:

Type.....front, above engine, three-seat

#### Specification of 15600 kg gross weight vehicle:

Maximum speed, not less, km/h  
 (At application of trunks of firm MICHELIN).....165  
 Maximum gradient, not less, (%).....36  
 Outer turning radius, m.....11.3

#### KAMAZ Incorporated

29, M. Dzhailil av., Naberezhnye Chelny,  
 Tatarstan, Russian Federation, 423808  
 phone: +7(8552) 42-2665, 55-4086  
 fax: +7(8552) 55-4167  
 http://www.kamaz.net



#### Foreign Trade Company KAMAZ

Naberezhnye Chelny:  
 phone.: +7(8552) 53-2404, phone/fax: 37-1816  
 Moscow: phone/fax: +7(095) 911-3134  
 E-mail: agesk@kamaztrade.ru  
 http://www.kamaztrade.ru

EURO-2

# KAMAZ-6350



NEW



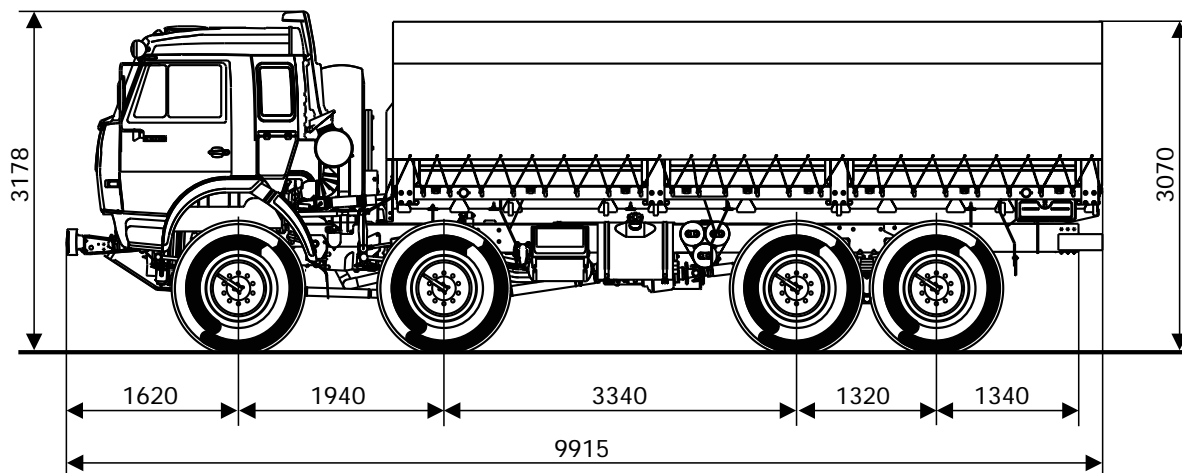

Truck dimension at curb weight

The right-side steering control is available

## KAMAZ - 6350 (8x8)

### Specifications

#### Weights and Loads:

Load carrying capacity, kg.....14000  
Gross weight, kg.....26300

#### Engine:

Model.....740.50-360 (EURO-2)  
Type.....diesel turbocharged, with intercooler  
Rated horsepower, gross, kw (H.P.).....265 (360)  
at crankshaft rotation, rpm.....2200  
Maximum torque, Nm (kgfm).....1431 (146)  
at crankshaft rotation, rpm.....1200-1400  
Arrangement and number of cylinders.....V type, 8  
Displacement, l.....11,76  
Cylinder diameter/Piston stroke, mm.....120/130  
Compression ratio.....16

#### Electrical equipment:

Voltage, V.....24  
Storage batteries, V/Ahr.....2612/190  
Generator, V.....28

#### Clutch:

Model.....ZF SACHS MFZ-430  
Type.....diaphragm type, one-plate  
Drive.....hydraulic with pneumatic booster

#### Gearbox:

Model.....ZF 16S 151  
Type.....mechanical, sixteen-speed  
Control.....mechanical, remote

#### Transfer case:

Model.....ZF Steyer

#### Wheels and tyres:

Wheel type.....disc  
Tyre type.....pneumatic, pressure adjustment  
Rim size.....12.2-20.9 (310-533)  
Tyre size.....425/85 R21 (1260x425-533P)

#### Cab:

Type.....front, above engine, three-seat  
Execution.....with sleeping berth

#### Truck bed:

Bed.....metal, with drop sides,  
equipped with removable frame and canopy  
Inner size, mm.....6600 x 2420

#### Specification for truck of 26300 kg gross weight:

Max speed, not less, km/h.....85  
Slope angle, not less, grades (%).....31 (60)  
Outer overall turning radius, m.....13,9  
Maximum fordable depth with pre-starting procedure, m.....1,75  
Ditch width, m.....1,4  
Vertical wall maximum height, not less, m.....0,55

KAMAZ Incorporated  
29, M. Dzhaliil av., Naberezhnye Chelny,  
Tatarstan, Russian Federation, 423808  
phone: +7(8552) 42-2665, 55-4086  
fax: +7(8552) 55-4167  
<http://www.kamaz.net>



Foreign Trade Company KAMAZ  
Naberezhnye Chelny:  
phone.: +7(8552) 53-2404, phone/fax: 37-1816  
Moscow: phone/fax: +7(095) 911-3134  
E-mail: [agesk@kamaztrade.ru](mailto:agesk@kamaztrade.ru)  
<http://www.kamaztrade.ru>

# KAMAZ-53215



© Advertising T&C KAMAZ



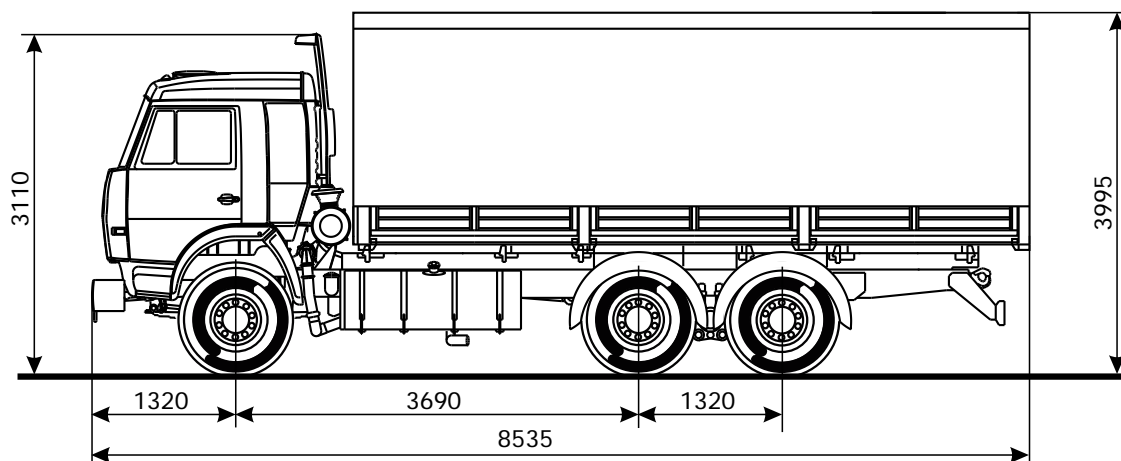

## KAMAZ - 53215 (6x4)

### Specifications

#### Weights and Load Capacities:

Vehicle load carrying capacity, kg.....	11000
Gross weight, kg.....	19355
Trailer gross weight, kg.....	14000
Road train allowed gross weight, kg.....	33355

#### Engine:

Model.....	740.11-240
Type.....	diesel, turbocharged
Rated horsepower, kw (H.P.).....	176 (240)
at crankshaft rotation, rpm.....	2200
Maximum torque, Nm (kgcm).....	834 (85)
at crankshaft rotation, rpm.....	1200-1600
Arrangement and number of cylinders.....	V-shape, 8
Displacement, l.....	10.85
Cylinder diameter and piston stroke, mm.....	120/120
Compression ratio.....	16

#### Electrics:

Voltage, V.....	24
Storage batteries, V/Ah.....	2x12/190
Generator, V.....	28

#### Clutch:

Type.....	friction, dry, two-plate, mod. 142
Drive.....	hydraulic with pneumatic booster

#### Gearbox:

Type.....	mechanical, ten-speed					
Control.....	mechanical, remote					
Gear ratios at gears:						
1	2	3	4	5	Rev.	
7.82	4.03	2.50	1.53	1.00	7.38	
6.38	3.29	2.04	1.25	0.815	6.02	

#### Brakes:

Drive.....	pneumatic
Size: drum diameter, mm.....	400
Brake linings width, mm.....	140
Brake linings total area, sq.cm.....	6300

#### Wheels and Tyres:

Wheel type.....	disc
Tyre type.....	pneumatic, tube
Rim size.....	7.0-20 (178-508)
Tyre size.....	10.00 R20 (280 R508)

#### Cab:

Type.....	front, above engine, three-seat
Option.....	with a sleeper

#### Specification of 19355 kg gross weight vehicle:

Maximum speed, not less, km/h.....	90
Maximum gradient, not less, %.....	25

#### KAMAZ Incorporated

29, M. Dzhailil av., Naberezhnye Chelny,  
Tatarstan, Russian Federation, 423808  
phone: +7(8552) 42-2665, 55-4086  
fax: +7(8552) 55-4167  
<http://www.kamaz.net>



#### Foreign Trade Company KAMAZ

Naberezhnye Chelny:  
phone.: +7(8552) 53-2404, phone/fax: 37-1816  
Moscow: phone/fax: +7(095) 911-3134  
E-mail: [agesk@kamaztrade.ru](mailto:agesk@kamaztrade.ru)  
<http://www.kamaztrade.ru>

# KAMAZ

## 65115 - 017-13



© Advertising T&FC KAMAZ



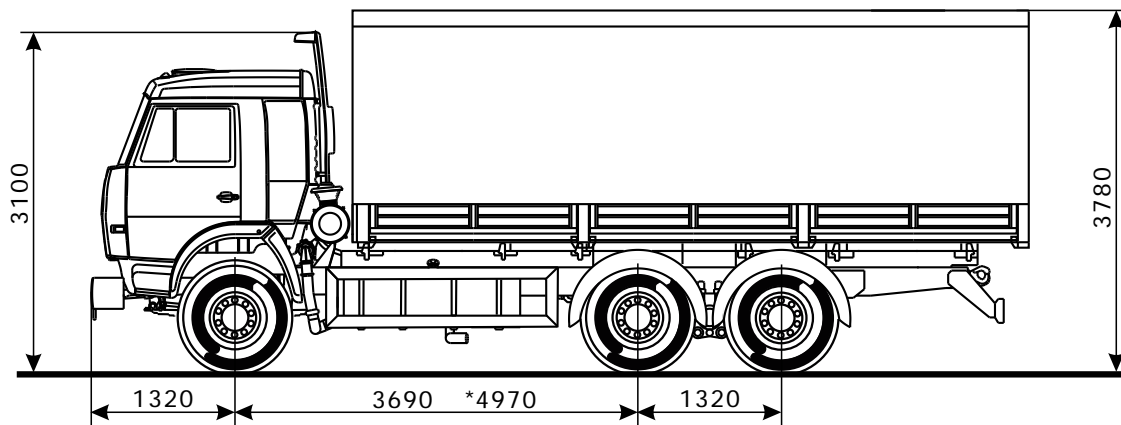

## KAMAZ - 65115-017-13 (6x4)

### Specifications

#### Weights and Load Capacities:

Vehicle load carrying capacity, kg .....	13600.....	*15000
Vehicle gross weight, kg .....	22400.....	*24000
front axle load, kg .....	4400.....	*6000
rear axle load, kg .....	18000.....	*18000
Total mass of a t.....	14000.....	*14000
Allowed total road train mass, kg .....	36400.....	*38000

#### Engine:

Model .....	740.13-260 (EURO-1)
Type .....	diesel, turbocharged
Rated horsepower, kwt (H.P.) .....	191 (260)
at crankshaft rotation, rpm .....	2200
Maximum torque, Nm (kgcm) .....	931 (95)
at crankshaft rotation, rpm .....	1300-1500
Arrangement and number of cylinders .....	V-shape, 8
Displacement, l .....	10,85
Cylinder diameter and piston stroke, mm .....	120/120
Compression ratio .....	17

#### Electrics:

Voltage, V .....	24
Storage batteries, V/Ah .....	2612/190

#### Clutch:

Model .....	17
Type .....	diaphragm, two-plate
Drive .....	hydraulic with pneumatic booster

#### Gearbox:

Type .....	mechanical, ten-speed					
Control .....	mechanical, remote					
Gear ratios at gears:						
1	2	3	4	5	Rev.	
7,82	4,03	2,50	1,53	1,000	7,38	
6,38	3,29	2,04	1,25	0,815	6,02	

#### Brakes:

Drive .....	pneumatic
Drum diameter, mm .....	400
Brake lining width, mm .....	140
Brake linings total area, sq.cm .....	6300

#### Wheels and Tyres:

Wheel type .....	disc
Tyre type .....	pneumatic, radial
Rim size .....	7,5-20
Tyre size .....	11,00 R20

#### Cab:

Type .....	front, located above engine
Execution .....	with sleeper

#### Platform:

Type .....	metal, demountable frame, tent	
Inside length, mm .....	6100 .....	*7800
Inside width, mm .....	2320.....	*2420

#### Specification of 38000 kg gross weight vehicle:

Maximum speed, not less, km/h .....	90
Maximum gradient, not less, % .....	18

**KAMAZ Incorporated**  
 29, M. Dzhilil av., Naberezhnye Chelny,  
 Tatarstan, Russian Federation, 423808  
 phone: +7(8552) 42-2665, 55-4086  
 fax: +7(8552) 55-4167  
<http://www.kamaz.net>



**Foreign Trade Company KAMAZ**  
 Naberezhnye Chelny:  
 phone.: +7(8552) 53-2404, phone/fax: 37-1816  
 Moscow: phone/fax: +7(095) 911-3134  
 E-mail: [agesk@kamaztrade.ru](mailto:agesk@kamaztrade.ru)  
<http://www.kamaztrade.ru>



EURO-2

# KAMAZ-65117



© Advertising T&FC KAMAZ

NEW



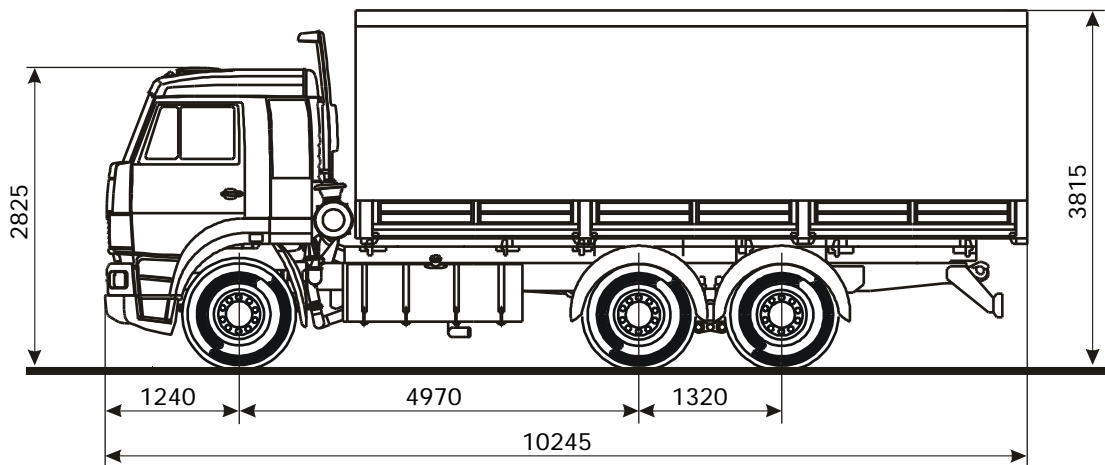

Truck dimension at curb weight

The right-side steering control is available

## KAMAZ - 65117 (6x4)

### Specifications

#### Weights and Loads:

Load carrying capacity, kg.....	14000
Gross weight, kg.....	24000
front axle load, kg .....	6000
rear axle load, kg .....	18000
Trailer gross weight, kg.....	14000
Road train allowed gross weight, kg.....	38000

#### Engine:

Model.....	740.30-260 (Euro 2)
Type.....	diesel turbo
Rated horsepower, h.p.(kW).....	191 (260)
at crankshaft rotation, rpm.....	2200
Maximum torque, kgfm (Nm).....	1079 (110)
at crankshaft rotation, rpm.....	1400
Arrangement and number of cylinders.....	V, 8
Displacement, l.....	10,85
Diameter/Piston stroke, mm.....	120/130
Compression ratio.....	17

#### Electrical equipment:

Voltage, V.....	24
Storage batteries, V/Ahr.....	2612/190
Alternator, V.....	28

#### Clutch:

Model.....	ZF SACHS MFZ-430
Type.....	diafraghm type, dry, one-plate
Drive.....	hydraulic with pneumatic booster

#### Gearbox:

Model.....	ZF 9S 109
Type.....	mechanical, 9-speed
Control.....	mechanical, remote

#### Brakes:

Drive.....	pneumatic
Drum diametre, mm.....	400
Brake linings width, mm.....	140
Brake linings total area, sq.cm.....	6300

#### Wheels and tyres:

Wheel type.....	discless
Tyre type.....	pneumatic, radial
Rim size.....	7,5-20
Tyre size.....	11,00 R20

#### Cab:

Type.....	front, above engine, three-seat
Execution.....	sleeper

#### Truck bed:

Bed.....	metal, with drop sides, equipped with removable frame and canopy
Inner size, mm.....	7800 x 2420

#### Specification for Chassis of 24000 kg gross weight:

Max speed, km/h.....	100
Max slope angle at gross vehicle weight, % .....	25

**KAMAZ Incorporated**  
29, M. Dzhilil av., Naberezhnye Chelny,  
Tatarstan, Russian Federation, 423808  
phone: +7(8552) 42-2665, 55-4086  
fax: +7(8552) 55-4167  
<http://www.kamaz.net>



**Foreign Trade Company KAMAZ**  
Naberezhnye Chelny:  
phone.: +7(8552) 53-2404, phone/fax: 55-2992  
Moscow: phone/fax: +7(095) 911-3134  
E-mail: [agesk@kamaztrade.ru](mailto:agesk@kamaztrade.ru)  
<http://www.kamaztrade.ru>

# KAMAZ-44108



© Advertising T&C KAMAZ



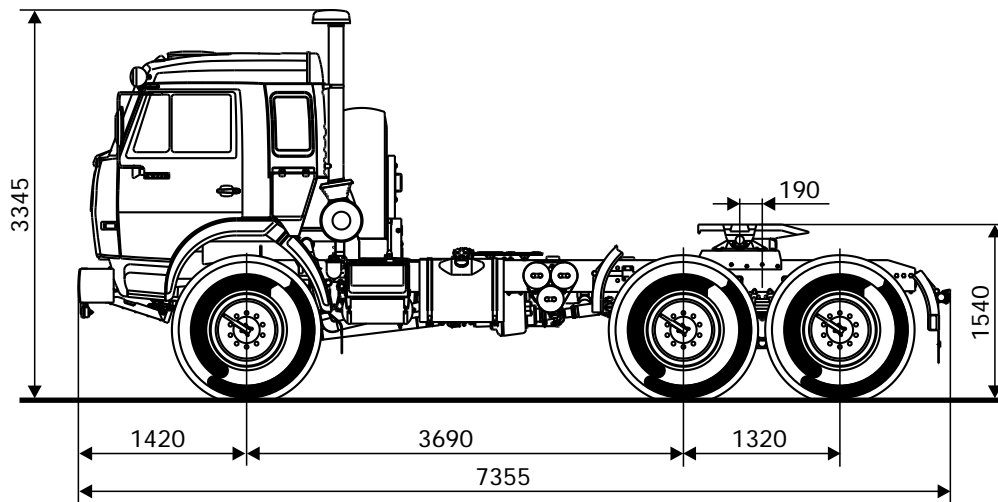

Truck dimension at curb weight

## KAMAZ - 44108 (6x6)

### Specifications

#### Weights and Load Capacities:

Gross weight, kg.....	19000
Front axle load, kg.....	5443
Rear axle load, kg.....	13565
Fifth wheel load, kg.....	10000
Trailer gross weight, kg.....	23000
Road train gross weight, kg.....	32000

#### Engine:

Model.....	740.13-260(Euro-1)
Type.....	diesel, turbocharged
Rated horsepower, kwt (H.P.).....	191 (260)
at crankshaft rotation, rpm.....	2200
Maximum torque, Nm (kgcm).....	932 (95)
at crankshaft rotation, rpm.....	1300-1500
Arrangement and number of cylinders.....	V-shape, 8
Displacement, l.....	10.85
Cylinder diametre and piston stroke, mm.....	120/120
Compression ratio.....	17

#### Electrics:

Voltage, V.....	24
Storage batteries, V/Ah.....	2x12/190
Generator, V.....	28

#### Clutch:

Type.....	diaphragm, two-plate, mod.17
Drive.....	hydraulic with pneumatic booster

#### Gearbox:

Type.....	mechanical, ten-speed
Control.....	mechanical, remote

Gear ratios at gears:

1	2	3	4	5	Rev.
7.82	4.03	2.50	1.53	1.00	7.38
6.38	3.29	2.04	1.25	0.815	6.02

#### Transfer Case:

Type.....	mechanical, two-speed with lockable interaxle differential
Control.....	pneumatic
Gear ratio of high/low gears.....	1.692/0.917

#### Brakes:

Drive.....	pneumatic
Size: drum diametre, mm.....	400
Brake linings width, mm.....	140
Brake linings total area, sq.cm.....	6300

#### Wheels and Tyres:

Wheel type.....	disc
Tyre type.....	pneumatic, pressure adjustment
Rim size.....	12,2-20,9 (310-533)
Tyres.....	425/85 R21 (1260x425-533P)

#### Cab:

Type.....	front, above engine, three-seat
Execution.....	highroof, sleeper

#### Specification of 32000 kg gross weight vehicle:

Maximum speed, not less, km/h.....	80
Maximum gradient, not less, %.....	18

#### KAMAZ Incorporated

29, M. Dzhilil av., Naberezhnye Chelny,  
Tatarstan, Russian Federation, 423808  
phone: +7(8552) 42-2665, 55-4086  
fax: +7(8552) 55-4167  
<http://www.kamaz.net>



#### Foreign Trade Company KAMAZ

Naberezhnye Chelny:  
phone.: +7(8552) 53-2404, phone/fax: 37-1816  
Moscow: phone/fax: +7(095) 911-3134  
E-mail: [agesk@kamaztrade.ru](mailto:agesk@kamaztrade.ru)  
<http://www.kamaztrade.ru>

# KAMAZ-54115



© Advertising T&C KAMAZ



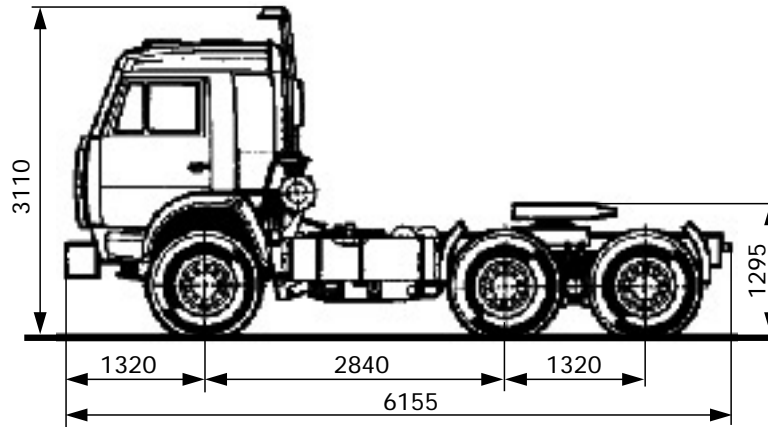

Truck dimension at curb weight

## KAMAZ - 54115 (6x4)

### Specifications

#### Weights and Load Capacities:

Fifth wheel coupler load, kg.....	12000
Gross weight, kg.....	19150
Trailer gross weight, kg.....	27000
Road train allowable gross weight.....	34150

#### Engine:

Model.....	740.11-240 (Euro-1)
Type.....	diesel, turbocharged
Rated horsepower, kw (H.P.).....	176 (240)
at crankshaft rotation, rpm.....	2200
Maximum torque, Nm (kgcm).....	834 (85)
at crankshaft rotation, rpm.....	1200-1600
Arrangement and number of cylinders.....	V-shape, 8
Displacement, l.....	10.85
Cylinder diameter and piston stroke, mm.....	120/120
Compression ratio.....	16

#### Electrics:

Voltage, V.....	24
Storage batteries, V/Ah.....	2x12/190
Generator, V.....	28

#### Clutch:

Type.....	friction, dry, two-plate, mod. 142
Drive.....	hydraulic with pneumatic booster

#### Gearbox:

Type.....	mechanical, ten-speed					
Control.....	mechanical, remote					
Gear ratios at gears:						
1	2	3	4	5	Rev.	
7.82	4.03	2.50	1.53	1.00	7.38	
6.38	3.29	2.04	1.25	0.815	6.02	

#### Brakes:

Drive.....	pneumatic
Size: drum diameter, mm.....	400
Brake linings width, mm.....	140
Brake linings total area, sq.cm.....	6300

#### Wheels and Tyres:

Wheel type.....	disc
Tyre type.....	pneumatic, tube
Rim size.....	7.0-20 (178-508)
Tyre size.....	10.00 R20 (280 R508)

#### Cab:

Type.....	front, above engine, three-seat
Option.....	with a sleeper

#### Specification of 34150 kg gross weight vehicle:

Maximum speed, not less, km/h.....	90
Maximum gradient, not less, %.....	18

#### KAMAZ Incorporated

29, M. Dzhailil av., Naberezhnye Chelny,  
Tatarstan, Russian Federation, 423808  
phone: +7(8552) 42-2665, 55-4086  
fax: +7(8552) 55-4167  
<http://www.kamaz.net>



#### Foreign Trade Company KAMAZ

Naberezhnye Chelny:  
phone.: +7(8552) 53-2404, phone/fax: 37-1816  
Moscow: phone/fax: +7(095) 911-3134  
E-mail: [agesk@kamaztrade.ru](mailto:agesk@kamaztrade.ru)  
<http://www.kamaztrade.ru>

EURO-2

# KAMAZ-5460



© Advertising T&C KAMAZ

NEW



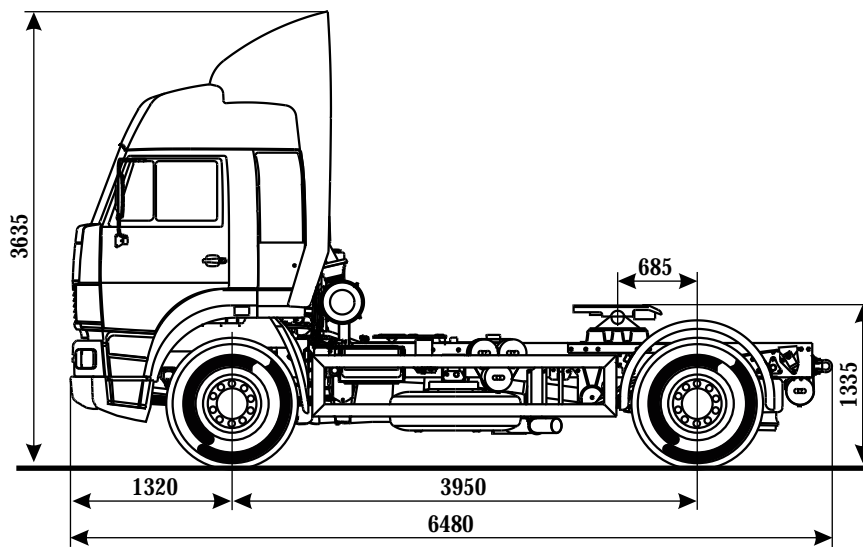

Truck dimension at curb weight

The right-side steering control is available

## KAMAZ - 5460 (4x2)

### Specifications

#### Weights and Loads:

Vehicle curb weight, kg.....	7050
Fifth wheel load, kg.....	10800
Gross weight, kg.....	18000
Gross semitrailer weight, kg.....	33000
Gross road train weight, kg.....	40000

#### Engine:

Model.....	740.50-360
Type.....	diesel turbo, OHB
Rated horsepower, h.p.(kW).....	360 (265)
at crankshaft rotation, rpm.....	2200
Maximum torque, kgfm (Nm).....	146 (1431)
at crankshaft rotation, rpm.....	1200-1400
Arrangement and number of cylinders.....	V, 8
Displacement, l.....	11,76
Diameter/Piston stroke, mm.....	120/130
Compression ratio.....	16

#### Electrical equipment:

Voltage, V.....	24
Storage batteries, V/Ahr.....	2612/190
Alternator, V.....	28

#### Clutch:

Model.....	ZF SACHS MFZ-430
Type.....	diaphragm type, dry, one-plate
Drive.....	hydraulic with pneumatic booster

#### Gearbox:

Model.....	ZF 16S 151
Type.....	mechanical, 16-speed
Control.....	mechanical, remote

#### Brake system:

Work system.....	pneumatic
Brake devices.....	of drum-tupe equipped with levels with automatic control of clearance ("HALDEX" - Sweden)
Air-drier.....	adsorption (WABCO - Germany)
Anti-block-system.....	KNORR BREMSE (Germany) (by consumer order)

#### Wheels and tyres:

Wheel type.....	disc-type
Tyre type.....	pneumatic, radial
Rim size.....	8.25-22,5; 9.0-22,5
Tyre size.....	315/70R22,5

#### Cab:

Type.....	front, above engine, three-seat
Execution.....	sleepper

#### Specification for Road Train of 40000 kg gross weight:

Max speed, km/h.....	90
Max slope angle at gross vehicle weight .....	18

**KAMAZ-5460-06 is designed to be used in roads with axle load capacity up to 10 tons.**

**Highway KAMAZ-5460-06 tractor truck is intended for transportation of different cargo by road train running on the roads designed for vehicles with axle load capacity up to 10 tons.**

**The truck features a cab of increased comfort with improved inner and outer side.**

**The truck design meets current requirements set by domestic and foreign legislation covering vehicles of the similar class and purpose.**

**KAMAZ Incorporated**  
29, M. Dzhailil av., Naberezhnye Chelny,  
Tatarstan, Russian Federation, 423808  
phone: +7(8552) 42-2665, 55-4086  
fax: +7(8552) 55-4167  
<http://www.kamaz.net>



**Foreign Trade Company KAMAZ**  
Naberezhnye Chelny:  
phone.: +7(8552) 53-2404, phone/fax: 37-1816  
Moscow: phone/fax: +7(095) 911-3134  
E-mail: [agesk@kamaztrade.ru](mailto:agesk@kamaztrade.ru)  
<http://www.kamaztrade.ru>



EURO-2

# KAMAZ-6460



© Advertising T&FC KAMAZ

NEW



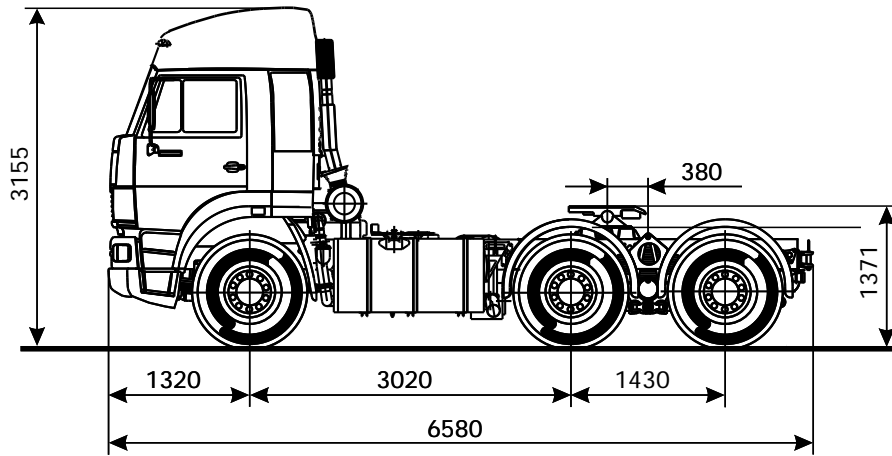

Truck dimension at curb weight

The right-side steering control is available

## KAMAZ - 6460 (6x4)

### Specifications

#### Weights and Loads:

Fifth wheel load, kg.....	16500
Gross weight, kg.....	26000
Gross semitrailer weight, kg.....	36500
Gross road train weight, kg.....	46000

#### Engine:

Model.....	740.50-360
Type.....	diesel turbo, OHB
Rated horsepower, h.p.(kW).....	360 (265)
at crankshaft rotation, rpm.....	2200
Maximum torque, kgfm (Nm).....	150(1470)
at crankshaft rotation, rpm.....	1300-1500
Arrangement and number of cylinders.....	V, 8
Displacement, l.....	11,76
Diameter/Piston stroke, mm.....	120/130
Compression ratio.....	16,8

#### Electrical equipment:

Voltage, V.....	24
Storage batteries, V/Ahr.....	2612/190
Alternator, V.....	28

#### Clutch:

Model.....	ZF SACHS MFZ-430
Type.....	diafraghm type, dry, one-plate
Drive.....	hydraulic with pneumatic booster

#### Gearbox:

Type.....	ZF16S-151...mechanical, 16-speed
Control.....	mechanical, remote

#### Brake system:

Work system.....	pneumatic
Brake devices.....	of drum-type equipped with levels with automatic control of clearece ("HALDEX" - Sweden)
Air-drier.....	adsorption (WABCO - Germany)
Anti-block-system.....	KNORR BREMSE (Germany) (by consumer order)

#### Wheels and tyres:

Wheel type.....	disc-type
Tyre type.....	pneumatic, radial
Rim size.....	8.5-20
Tyre size.....	12.00 R20

#### Cab:

Type.....	front, above engine
Execution.....	sleeper

#### Specification for Road Train of 46000 kg gross weight:

Max speed, km/h.....	90
Max slope angle at gross vehicle, weight.....	18

#### KAMAZ Incorporated

29, M. Dzhallil av., Naberezhnye Chelny,  
Tatarstan, Russian Federation, 423808  
phone: +7(8552) 42-2665, 55-4086  
fax: +7(8552) 55-4167  
<http://www.kamaz.net>



#### Foreign Trade Company KAMAZ

Naberezhnye Chelny:  
phone.: +7(8552) 53-2404, phone/fax: 37-1816  
Moscow: phone/fax: +7(095) 911-3134  
E-mail: [agesk@kamaztrade.ru](mailto:agesk@kamaztrade.ru)  
<http://www.kamaztrade.ru>

# KAMAZ

65115 - 013-13



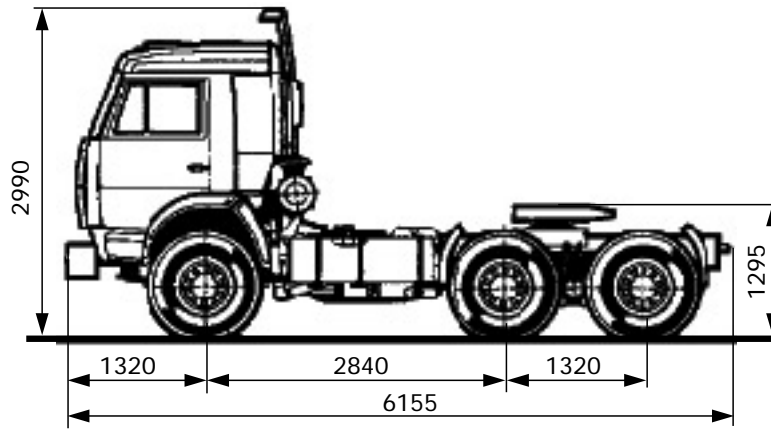

Truck dimension at curb weight

## KAMAZ - 65115 - 013-13 (6x4)

### Specifications

#### Weights and Load Capacities:

Fifth wheel coupler load, kg.....	15000
Gross weight, kg.....	22600
Trailer gross weight, kg.....	29000
Road train allowable gross weight.....	36600

#### Engine:

Model.....	740.13-260
Type.....	diesel, turbocharged
Rated horsepower, kw (H.P.).....	191 (260)
at crankshaft rotation, rpm.....	2200
Maximum torque, Nm (kgcm).....	931 (95)
at crankshaft rotation, rpm.....	1300-1500
Arrangement and number of cylinders.....	V-shape, 8
Displacement, l.....	10.85
Cylinder diameter and piston stroke, mm.....	120/120
Compression ratio.....	17

#### Electrics:

Voltage, V.....	24
Storage batteries, V/Ah.....	2x12/190
Generator, V.....	28

#### Clutch:

Model.....	17
Type.....	diaphragm, two plate
Drive.....	hydraulic with pneumatic booster

#### Gearbox:

Type.....	mechanical, ten-speed					
Control.....	mechanical, remote					
Gear ratios at gears:						
1	2	3	4	5	Rev.	
7.82	4.03	2.50	1.53	1.00	7.38	
6.38	3.29	2.04	1.25	0.815	6.02	

#### Brakes:

Drive.....	pneumatic
Size: drum diameter, mm.....	400
Brake linings width, mm.....	140
Brake linings total area, sq.cm.....	6300

#### Wheels and Tyres:

Wheel type.....	disk
Tyre type.....	pneumatic, tube
Rim size.....	7.5-20 (190-508)
Tyre size.....	11.00 R20 (300 R508)

#### Cab:

Type.....	front, above engine, three-seat
Option.....	with a sleeper

#### Specification of 36600 kg gross weight vehicle:

Maximum speed, not less, km/h.....	90
Maximum gradient, not less, %.....	18



# KAMAZ-65116



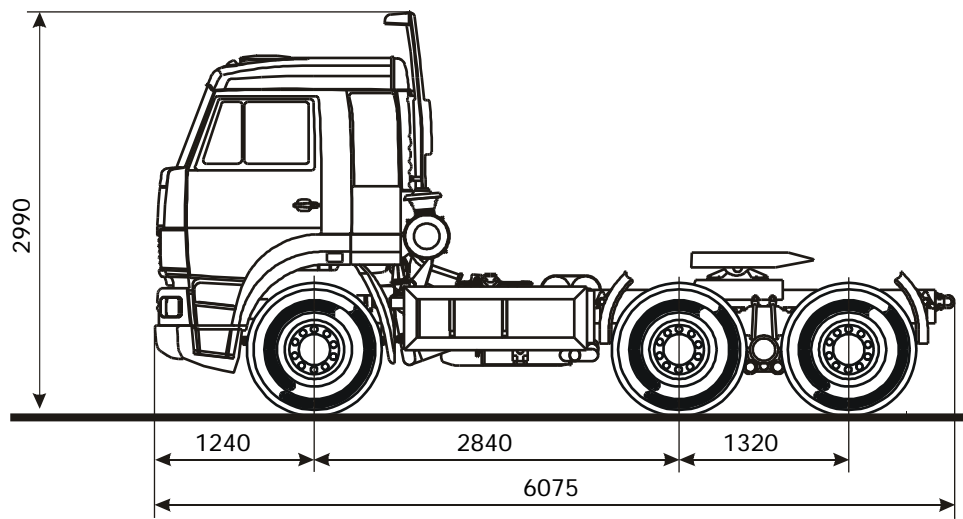

Truck dimension at curb weight  
The right-side steering control is available

## KAMAZ - 65116 (6x4)

### Specifications

#### Weights and Load Capacities:

Fifth wheel load, kg.....	15000
Gross weight, kg.....	22600
Semi-trailer gross weight, kg.....	29000
Road train gross weight, kg.....	36600

#### Engine:

Model.....	740.30-260 (Euro 2)
Type.....	diesel, turbocharged
Rated horsepower, gross, kwt (H.P.).....	191 (260)
at crankshaft rotation, rpm.....	2200
Maximum torque, Nm (kgcm).....	1079 (110)
at crankshaft rotation, rpm.....	1400
Arrangement and number of cylinders.....	V-shape, 8
Displacement, l.....	10.85
Cylinder diameter and piston stroke, mm.....	120/120
Compression ratio.....	17

#### Electrics:

Voltage, V.....	24
Storage batteries, V/Ah.....	2x12/190
Generator, V.....	28

#### Clutch:

Model.....	ZF SACHS MFZ-430
Type.....	diaphragm type, dry, one-plate
Drive.....	hydraulic with pneumatic booster

#### Gearbox:

Model.....	ZF 9 S 109
Type.....	mechanical, 9-speed
Control.....	mechanical, remote

#### Brakes:

Drive.....	pneumatic
Sizes: drum diameter, mm.....	400
Brake linings width, mm.....	140
Brake linings total area, sq.cm.....	6300

#### Wheels and Tyres:

Wheel type.....	disc
Tyre type.....	pneumatic, tube
Rim size.....	7.5-20
Tyre size.....	11.00 R20

#### Cab:

Type.....	front, above engine, three-seat
Option.....	with sleeper

#### Specification of 36600 kg gross weight vehicle:

Maximum speed, not less, km/h.....	100
Maximum gradient, not less, %.....	18

#### KAMAZ Incorporated

29, M. Dzhilil av., Naberezhnye Chelny,  
Tatarstan, Russian Federation, 423808  
phone: +7(8552) 42-2665, 55-4086  
fax: +7(8552) 55-4167  
<http://www.kamaz.net>



#### Foreign Trade Company KAMAZ

Naberezhnye Chelny:  
phone.: +7(8552) 53-2404, phone/fax: 37-1816  
Moscow: phone/fax: +7(095) 911-3134  
E-mail: [agesk@kamaztrade.ru](mailto:agesk@kamaztrade.ru)  
<http://www.kamaztrade.ru>

# KAMAZ-55111



© Advertising T&FC KAMAZ



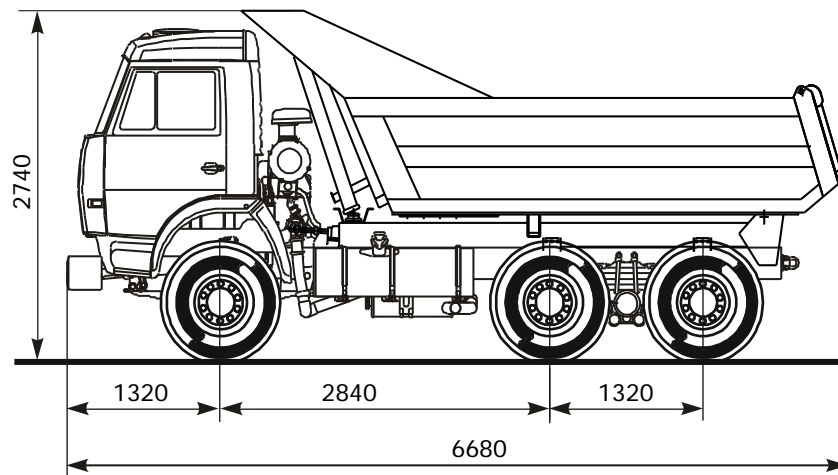

Truck dimension at curb weight

## KAMAZ - 55111 (6x4)

### Specifications

#### Weights and Load Capacities:

Vehicle load carrying capacity, kg.....	13000
Gross weight, kg.....	22200
Front axle load, kg.....	5500
Rear bogie load, kg.....	16700

#### Engine:

Model.....	740.11-240
Type.....	diesel, turbocharged
Rated horsepower, kw (H.P.).....	176 (240)
at crankshaft rotation, rpm.....	2200
Maximum torque, Nm (kgcm).....	834 (85)
at crankshaft rotation, rpm.....	1200-1600
Arrangement and number of cylinders.....	V-shape, 8
Displacement, l.....	10.85
Cylinder diameter and piston stroke, mm.....	120/120
Compression ratio.....	16

#### Electrics:

Voltage, V.....	24
Storage batteries, V/Ah.....	2x12/190
Generator, V.....	28

#### Clutch:

Model.....	142
Type.....	diaphragm, two plate
Drive.....	hydraulic with pneumatic booster

#### Gearbox:

Type.....	mechanical, ten-speed
Control.....	mechanical, remote

#### Gear ratios at gears:

1	2	3	4	5	Rev.
7.82	4.03	2.50	1.53	1.00	7.38
6.38	3.29	2.04	1.25	0.815	6.02

#### Brakes:

Drive.....	pneumatic
Size: drum diameter, mm.....	400
Brake linings width, mm.....	140
Brake linings total area, sq.cm.....	6300

#### Wheels and Tyres:

Wheel type.....	disc
Tyre type.....	pneumatic, tube
Rim size.....	7.0-20 (178-508)
Tyre size.....	10.00R20 (280 R508)

#### Cab:

Type.....	front, above engine, three-seat
Option.....	short

#### Dump Truck Platform:

Platform capacity, cub.m.....	6.6
Platform lifting angle, grades.....	60
Dumping direction.....	backward

#### Specification of 22200 kg gross weight vehicle:

Maximum speed, not less, km/h.....	90
Maximum gradient, not less, %.....	25

#### KAMAZ Incorporated

29, M. Dzhallil av., Naberezhnye Chelny,  
Tatarstan, Russian Federation, 423808  
phone: +7(8552) 42-2665, 55-4086  
fax: +7(8552) 55-4167  
<http://www.kamaz.net>



#### Foreign Trade Company KAMAZ

Naberezhnye Chelny:  
phone.: +7(8552) 53-2404, phone/fax: 37-1816  
Moscow: phone/fax: +7(095) 911-3134  
E-mail: [agesk@kamaztrade.ru](mailto:agesk@kamaztrade.ru)  
<http://www.kamaztrade.ru>



EURO-2

# KAMAZ-65111



© Advertising T&FC KAMAZ

NEW



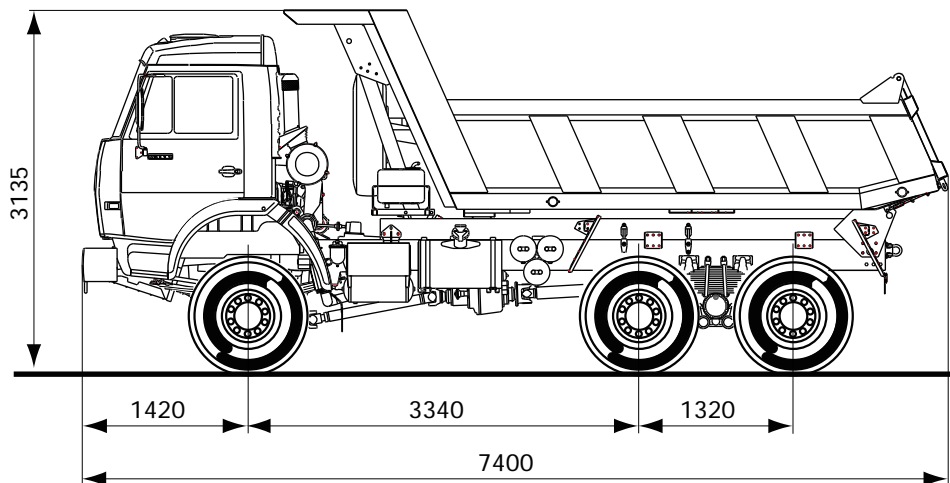

Truck dimension at curb weight

## KAMAZ - 65111 (6x6)

### Specifications

#### Weights and Load Capacities:

Vehicle load carrying capacity, kg.....	14000
Gross weight, kg.....	24500
Front axle load, kg.....	6000
Rear bogie load, kg.....	18500

#### Engine:

Model.....	740.13-260(Euro-1)
Type.....	diesel, turbocharged
Rated horsepower, kw (H.P.).....	191 (260)
at crankshaft rotation, rpm.....	2200
Maximum torque, Nm (kgcm).....	931 (95)
at crankshaft rotation, rpm.....	1300-1500
Arrangement and number of cylinders.....	V-shape, 8
Displacement, l.....	10.85
Cylinder diameter and piston stroke, mm.....	120/120
Compression ratio.....	17

#### Electrics:

Voltage, V.....	24
Storage batteries, V/Ah.....	2x12/190
Generator, V.....	28

#### Clutch:

Type.....	diaphragm, two-plate, mod.17
Drive.....	hydraulic with pneumatic booster

#### Gearbox:

Type.....	mechanical, five-speed
Control.....	mechanical, remote

#### Transfer case:

Type.....	mechanical, two-speed with lockable interaxle differential
Control.....	pneumatic

#### Brakes:

Drive.....	pneumatic
Size: drum diameter, mm.....	400
Brake linings width, mm.....	140
Brake linings total area, sq.cm.....	6300

#### Wheels and Tyres:

Wheel type.....	disc
Tyre type.....	pneumatic, tube
Rim size.....	7.5-20
Tyre size.....	11.00 R20

#### Cab:

Type.....	front, above engine
Option.....	short

#### Dump Truck Platform:

Platform capacity, cub.m.....	8.2
Platform lifting angle, grades.....	52
Dumping direction.....	backward

#### Specification of 24500 kg gross weight vehicle:

Maximum speed, not less, km/h.....	80
Maximum gradient, not less, %.....	30

#### KAMAZ Incorporated

29, M. Dzhallil av., Naberezhnye Chelny,  
Tatarstan, Russian Federation, 423808  
phone: +7(8552) 42-2665, 55-4086  
fax: +7(8552) 55-4167  
<http://www.kamaz.net>



#### Foreign Trade Company KAMAZ

Naberezhnye Chelny:  
phone.: +7(8552) 53-2404, phone/fax: 37-1816  
Moscow: phone/fax: +7(095) 911-3134  
E-mail: [agesk@kamaztrade.ru](mailto:agesk@kamaztrade.ru)  
<http://www.kamaztrade.ru>

# KAMAZ

## 65115 - 016-13



© Advertising T&FC KAMAZ

**NEW**



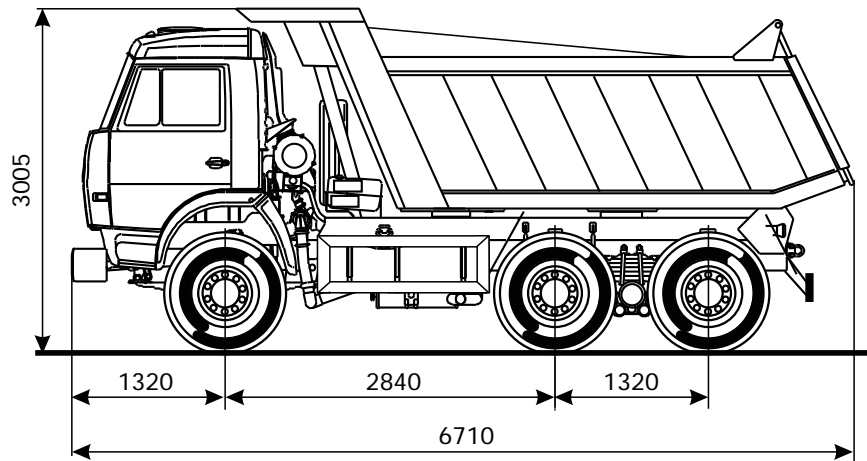

Truck dimension at curb weight

## KAMAZ - 65115 - 016-13 (6x4)

### Specifications

#### Weights and Load Capacities:

Vehicle load carrying capacity, kg.....	15000
Gross weight, kg.....	24800
Front axle load, kg.....	6000
Rear bogie load, kg.....	18800

#### Engine:

Model.....	740.13-260
Type.....	diesel, turbocharged
Rated horsepower, kw (H.P.).....	191 (260)
at crankshaft rotation, rpm.....	2200
Maximum torque, Nm (kgcm).....	931 (95)
at crankshaft rotation, rpm.....	1300-1500
Arrangement and number of cylinders.....	V-shape, 8
Displacement, l.....	10.85
Cylinder diametre and piston stroke, mm.....	120/120
Compression ratio.....	17

#### Electrics:

Voltage, V.....	24
Storage batteries, V/Ah.....	2x12/190
Generator, V.....	28

#### Clutch:

Model.....	17
Type.....	diaphragm, two plate
Drive.....	hydraulic with pneumatic booster

#### Gearbox:

Type.....	mechanical, ten-speed				
Control.....	mechanical, remote				
Gear ratios at gears:					
1	2	3	4	5	Rev.
7.82	4.03	2.50	1.53	1.00	7.38
6.38	3.29	2.04	1.25	0.815	6.02

#### Brakes:

Drive.....	pneumatic
Size: drum diametre, mm.....	400
Brake lining width, mm.....	140
Brake linings total area, sq.cm.....	6300

#### Wheels and Tyres:

Wheel type.....	disk
Tyre type.....	pneumatic, tube
Rim size.....	7.5-20 (190-508)
Tyre size.....	11.00 R20 (300 R508)

#### Cab:

Type.....	front, above engine, three-seat
Option.....	short

#### Dump Truck Platform:

Platform capacity, cub.m.....	11 (13)
Dumping direction.....	backward

#### Specification of 24800 kg gross weight vehicle:

Maximum speed, not less, km/h.....	80
Maximum gradient, not less, %.....	25

#### KAMAZ Incorporated

29, M. Dzhaliil av., Naberezhnye Chelny,  
Tatarstan, Russian Federation, 423808  
phone: +7(8552) 42-2665, 55-4086  
fax: +7(8552) 55-4167  
<http://www.kamaz.net>



#### Foreign Trade Company KAMAZ

Naberezhnye Chelny:  
phone.: +7(8552) 53-2404, phone/fax: 37-1816  
Moscow: phone/fax: +7(095) 911-3134  
E-mail: [agesk@kamaztrade.ru](mailto:agesk@kamaztrade.ru)  
<http://www.kamaztrade.ru>

EURO-2

# KAMAZ-6520



NEW



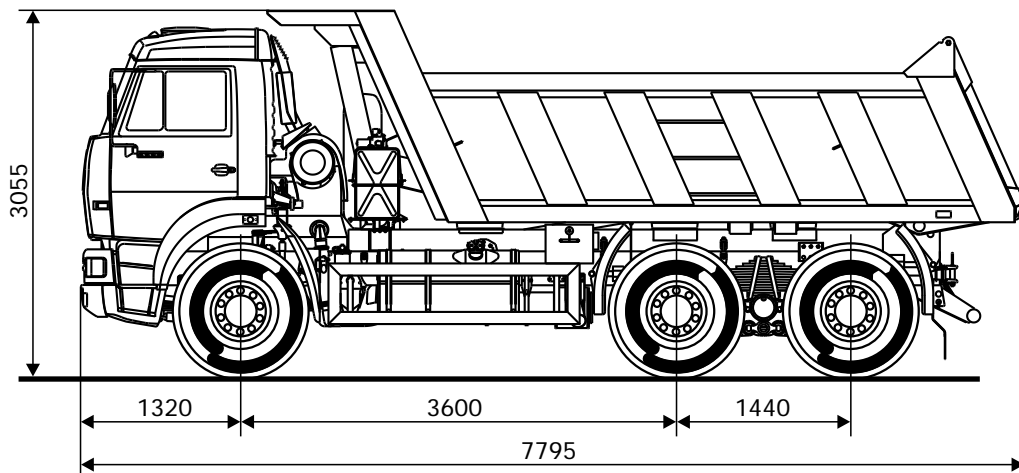

Truck dimension at curb weight

The right-side steering control is available

## KAMAZ - 6520 (6x4)

### Specifications

#### Weights and Load Capacities:

Vehicle load carrying capacity, kg.....	20000
Vehicle gross weight, kg.....	33100
Front axle load, kg.....	7400
Rear axle load, kg.....	25700

#### Engine:

Model.....	740.51-320 (EURO-2)
Type.....	diesel, turbocharged
Rated horsepower, kw (H.P.).....	235 (320)
at crankshaft rotation, rpm.....	2200
Maximum torque, Nm (kgcm).....	1225 (125)
at crankshaft rotation, rpm.....	1200-1500
Arrangement and number of cylinders.....	V-shape, 8
Displacement, l.....	11,76
Cylinder diameter and piston stroke, mm.....	120/130
Compression ratio.....	16

#### Electrics:

Voltage, V.....	24
Storage batteries, V/Ah.....	2612/190
Generator, V.....	28

#### Clutch:

Model.....	ZF SACHS MFZ-430
Type.....	Friction, dry, one-plate
Drive.....	Hydraulic with pneumatic booster

#### Gearbox:

Model.....	ZF 16S 151
Type.....	Mechanical, sixteen-speed
Control.....	Mechanical, remote

Gear ratios at gears:

1	2	3	4	5	6	7	8	Rev.
13,80	9,49	6,53	4,57	3,02	2,08	1,43	1,00	12,92
11,54	7,93	5,46	3,82	2,53	1,74	1,20	0,84	10,80

#### Final Drive:

Type.....Double, with central conic gear and planetary wheel gears

#### Brake system:

Work system.....pneumatic  
 Brake devices.....of drum-tupe  
 equipped with levels with automatic  
 control of clearece ("HALDEX" - Sweden)  
 Air-drier.....adsorption (WABCO - Germany)  
 Anti-block-system.....KNORR BREMSE (Germany)  
 (by consumer order)

#### Wheels and Tyres:

Wheel type.....Disc  
 Tyre type.....Pneumatic, radial  
 Rim size.....8.5-20 (216-508)  
 Tyre size.....12.00 R20 (320 R508)

#### Cab:

Type.....Front, located above engine, 3 seats  
 Option.....Without sleeping berth

#### Dump Truck Platform:

Platform capacity, cub.m.....12 (16)  
 Platform lifting angle, grades.....50  
 Dumping direction.....backward

#### Specification of 33100 kg gross weight vehicle:

Maximum speed, not less, km/h.....80  
 Maximum gradient, not less, %.....25

#### KAMAZ Incorporated

29, M. Dzhilil av., Naberezhnye Chelny,  
 Tatarstan, Russian Federation, 423808  
 phone: +7(8552) 42-2665, 55-4086  
 fax: +7(8552) 55-4167  
<http://www.kamaz.net>



#### Foreign Trade Company KAMAZ

Naberezhnye Chelny:  
 phone.: +7(8552) 53-2404, phone/fax: 37-1816  
 Moscow: phone/fax: +7(095) 911-3134  
 E-mail: [agesk@kamaztrade.ru](mailto:agesk@kamaztrade.ru)  
<http://www.kamaztrade.ru>

EURO-2

# KAMAZ-6522



© Advertising T&FC KAMAZ

NEW



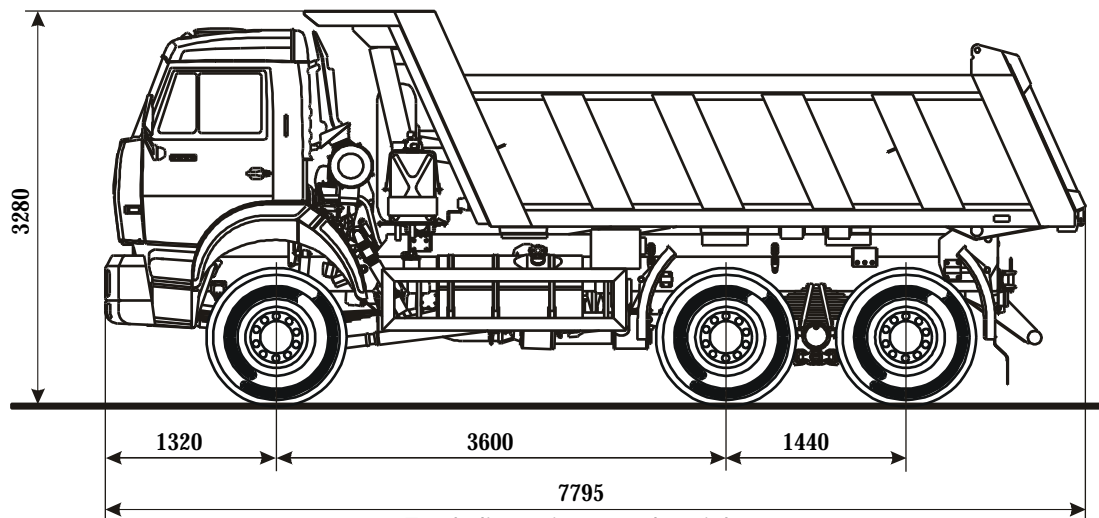

Truck dimension at curb weight  
The right-side steering control is available

## KAMAZ - 6522 (6x6)

### Specifications

#### Weights and Load Capacities:

Vehicle load carrying capacity, kg.....19000  
Vehicle gross weight, kg.....33100

#### Engine:

Model.....740.51-320 (EURO-2)  
Type.....diesel, turbocharged  
Rated horsepower, kw (H.P.).....235 (320)  
at crankshaft rotation, rpm.....2200  
Maximum torque, Nm (kgcm).....1225 (125)  
at crankshaft rotation, rpm.....1200-1500  
Arrangement and number of cylinders.....V-shape, 8  
Displacement, l.....11,76  
Cylinder diameter and piston stroke, mm.....120/130  
Compression ratio.....16

#### Electrics:

Voltage, V.....24  
Storage batteries, V/Ah.....2612/190  
Generator, V.....28

#### Clutch:

Model.....ZF SACHS MFZ-430  
Type.....Friction, dry, one-plate  
Drive.....Hydraulic with pneumatic booster

#### Gearbox:

Model.....ZF 16S 151  
Type.....Mechanical, sixteen-speed  
Control.....Mechanical, remote

#### Gear ratios at gears:

1	2	3	4	5	6	7	8	Rev.
13,80	9,49	6,53	4,57	3,02	2,08	1,43	1,00	12,92
11,54	7,93	5,46	3,82	2,53	1,74	1,20	0,84	10,80

#### Transfer Case:

Type.....mechanical, two-speed with lockable interaxle differential  
Control.....pneumatic  
Gear ratio of high/low gears.....1.48/1.00

#### Brakes:

Drive.....Pneumatic  
Drum diameter, mm.....420  
Brake lining width, mm.....180  
Brake linings total area, sq. cm.....7200

#### Wheels and Tyres:

Wheel type.....Disc  
Tyre type.....Pneumatic, radial  
Rim size.....8.5-20 (216-508)  
Tyre size.....12.00 R20 (320 R508)

#### Cab:

Type.....Front, located above engine, 3 seats  
Option.....short

#### Dump Truck Platform:

Platform capacity, cub.m.....12  
Platform lifting angle, grades.....50  
Dumping direction.....backward

#### Specification of 33100 kg gross weight vehicle:

Maximum speed, not less, km/h.....90  
Maximum gradient, not less, %.....30

#### KAMAZ Incorporated

29, M. Dzhaliil av., Naberezhnye Chelny,  
Tatarstan, Russian Federation, 423808  
phone: +7(8552) 42-2665, 55-4086  
fax: +7(8552) 55-4167  
<http://www.kamaz.net>



#### Foreign Trade Company KAMAZ

Naberezhnye Chelny:  
phone.: +7(8552) 53-2404, phone/fax: 37-1816  
Moscow: phone/fax: +7(095) 911-3134  
E-mail: [agesk@kamaztrade.ru](mailto:agesk@kamaztrade.ru)  
<http://www.kamaztrade.ru>



# KAMAZ-6540



© Advertising T&FC KAMAZ

**NEW**



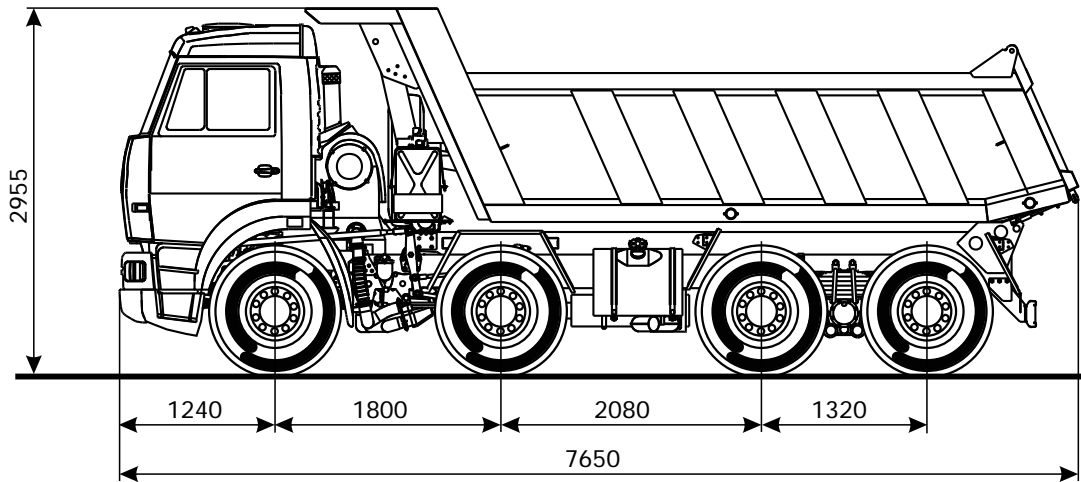

## KAMAZ - 6540 (8x4)

### Specifications

#### Weights and Load Capacities:

Vehicle load carrying capacity, kg.....	18500
Gross weight, kg.....	30500
First and second axles load, kg.....	12000
Rear bogie load, kg.....	18500

#### Engine:

Model.....	740.13-260 (E-1)
Type.....	diesel, turbocharged
Rated horsepower, kw (H.P.).....	191 (260)
at crankshaft rotation, rpm.....	2200
Maximum torque, Nm (kgcm).....	931 (95)
at crankshaft rotation, rpm.....	1300-1500
Arrangement and number of cylinders.....	V-shape, 8
Displacement, l.....	10.85
Cylinder diameter and piston stroke, mm.....	120/120
Compression ratio.....	17

#### Electrics:

Voltage, V.....	24
Storage batteries, V/Ah.....	2x12/190
Generator, V.....	28

#### Clutch:

Type.....	diaphragm, two-plate, mod.17
Drive.....	hydraulic with pneumatic booster

#### Gearbox:

Type.....	mechanical, ten-speed
Control.....	mechanical, remote

#### Gear ratios at gears:

1	2	3	4	5	Rev.
7.82	4.03	2.50	1.53	1.00	7.38
6.38	3.29	2.04	1.25	0.815	6.02

#### Brakes:

Drive.....	pneumatic
Size: drum diameter, mm.....	400
Brake linings width, mm.....	140
Brake linings total area, sq.cm.....	8400

#### Wheels and Tyres:

Wheel type.....	disc
Tyre type.....	pneumatic, tube
Rim size.....	7.5-20
Tyre size.....	11.00 R20

#### Cab:

Type.....	front, above engine, three-seat
Option.....	short

#### Dump Truck Platform:

Platform capacity, cub.m.....	11
Platform lifting angle, grades.....	55
Dumping direction.....	backward

#### Specification of 30500 kg gross weight vehicle:

Maximum speed, not less, km/h.....	85
Maximum gradient, not less, %.....	25

#### KAMAZ Incorporated

29, M. Dzhallil av., Naberezhnye Chelny,  
Tatarstan, Russian Federation, 423808  
phone: +7(8552) 42-2665, 55-4086  
fax: +7(8552) 55-4167  
<http://www.kamaz.net>



#### Foreign Trade Company KAMAZ

Naberezhnye Chelny:  
phone.: +7(8552) 53-2404, phone/fax: 37-1816  
Moscow: phone/fax: +7(095) 911-3134  
E-mail: [agesk@kamaztrade.ru](mailto:agesk@kamaztrade.ru)  
<http://www.kamaztrade.ru>

# FOR ALL ROADS AND CONDITIONS



**KAMAZ Incorporated**  
29, v. Dzhail Avenue,  
Naberezhnye Chelny  
Tatarstan, 423808 Russia



**KAMAZ Inc. offers**  
**a wide range**



**of KAMAZ trucks,**

**capacity from**

**4 up to 20 tons,**

**special purpose trucks,**

**chassis units, spare parts,**

**components and**

**assemblies as well**

**as guarantees service**

**support.**



**KAMAZ trucks**

**are operated throughout**

**the whole world,**

**under any road and**

**climatic conditions.**

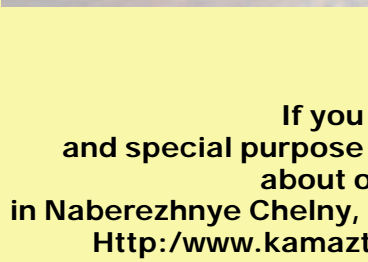

If you have any questions about sales of trucks  
and special purpose vehicles on KAMAZ chassis, spare parts,  
about organization of service, please contact us  
in Naberezhnye Chelny, phone/fax: +7 (8552) 37-1816, 53-2404  
Http://www.kamaztrade.ru E-mail:agesk@kamaztrade.ru  
in Moscow, phone/fax: +7 (095) 911-3134, 911-3121



# KAMAZ Incorporated

## **KAMAZ Incorporated**

29, M. Dzhallil av., Naberezhnye Chelny,  
Tatarstan, Russian Federation, 423808  
<http://www.kamaz.net>



## **KAMAZ Foreign Trade Company**

4, Rubanenko blvd., Naberezhnye Chelny,  
Tatarstan, Russian Federation, 423810

phone.: +7(8552) 53-2404, phone/fax: 37-1816

E-mail: [agesk@kamaztrade.ru](mailto:agesk@kamaztrade.ru) <http://www.kamaztrade.ru>

Moscow: phone/fax: +7(095) 911-3134

Kazan: phone.: +7(8432) 64-3152, fax: 64-3162